

Not Recommended for New Design



AP1516

150KHz, 3A PWM Buck DC/DC Converter + 1A Ultra Low Drop Regulator

■ Features

* Channel 1: simple switch

- Adjustable version output voltage range, 1.23V to 18V \pm 4% & Fixed 3.3V version
- 150KHz \pm 20% fixed switching frequency
- Voltage mode non-synchronous PWM control
- ON/OFF shutdown control input
- Operating voltage can be up to 20V
- Output load current: 3A
- Low power standby mode

* Channel 2: ultra low drop regulator

- Adjustable output voltage
- 0.6V Maximum Dropout voltage at 1.0A Load current
- Fast transient response
- Good noise rejection

* Channel 1 & Channel 2

- SOP-16L **Pb-free** package
- Built-in switching transistor on chip
- Thermal-shutdown and current-limit protection of each channel

■ Applications

- PC Motherboard
- LCD Monitor
- Graphic Card
- DVD-Video Player
- NIC/Switch
- Telecom Equipment
- ADSL Modem
- Printer and other Peripheral Equipment

■ Pin Assignments

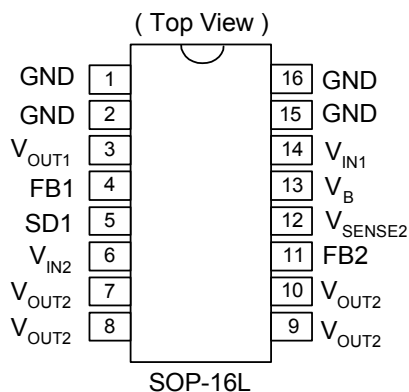

■ General Description

The Channel 1 is a step-down DC/DC converter, and own the ability of driving a 3A load without additional transistor component. Due to reducing the number of external component, the board space can be saved easily. The external shutdown function can be controlled by logic level and then come into standby mode. The internal compensation makes feedback control have good line and load regulation without external design. Regarding protected function, thermal shutdown is to prevent over temperature operating from damage, and current limit is against over current operating of the output switch. If current limit function occurred and V_{FB} is down to 0.5V below, the switching frequency will be reduced. The switching frequency of 150KHz thus allowing smaller sized filter components than what would be needed with lower frequency switching regulators. Other features include a guaranteed \pm 4% tolerance on output voltage under specified input voltage and output load conditions, and \pm 20% on the oscillator frequency.

The channel 2 is a 1A regulator with extremely low dropout voltage. This product is specifically designed to provide well regulated supply for applications requiring 2.8V or lower voltages from 3.3V power supplies where high efficiency of a switcher can be achieved without the cost and complexity associated with switching regulator.

■ Pin Descriptions

Name	Description
V _{IN1}	Operating voltage input of channel 1
V _B	Channel 2 bias voltage
V _{IN2}	Main power source of channel 2
V _{OUT1}	Channel 1 switching output
V _{OUT2}	Channel 2 output
FB1	Output1 voltage feedback control
FB2	Output2 voltage feedback control
SD1	Channel 1 ON/OFF shutdown
V _{SENSE2}	Channel 2 output sense pin
GND	Ground

Not Recommended for New Design



AP1516

150KHz, 3A PWM Buck DC/DC Converter + 1A Ultra Low Drop Regulator

Ordering Information

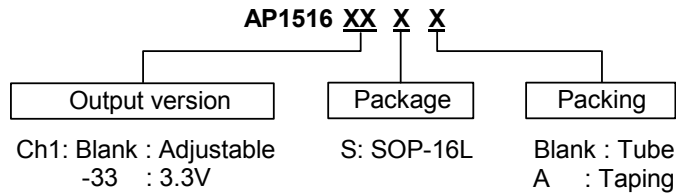

Block Diagram

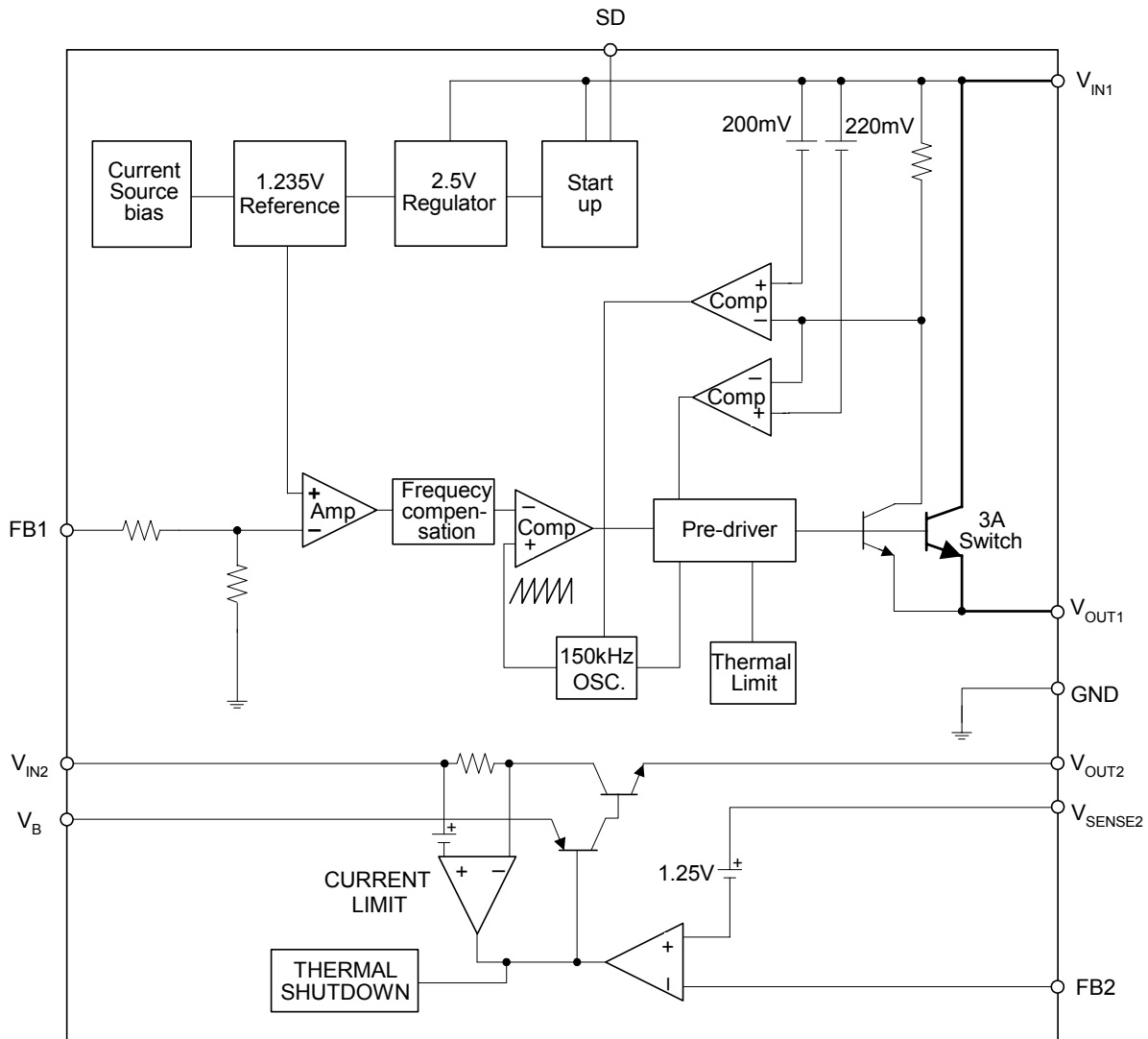

Not Recommended for New Design



AP1516

150KHz, 3A PWM Buck DC/DC Converter + 1A Ultra Low Drop Regulator

■ Absolute Maximum Ratings

Symbol	Parameter	Rating	Unit
$V_{IN1,B}$	Supply Voltage	+22	V
V_{IN2}	Supply Voltage	+14	V
V_{SD}	ON/OFF Pin Input Voltage	-0.3 to +18	V
V_{FB1}	Feedback Pin Voltage	-0.3 to +18	V
V_{OUT1}	Output Voltage to Ground	-1	V
P_D	Power Dissipation	Internally limited	W
T_{ST}	Storage Temperature	-65 to +150	°C
T_{OP}	Operating Temperature	-40 to +125	°C
V_{OP}	Operating Voltage	+4.5 to +22	V

■ Electrical Characteristics (All Output Voltage Versions)

Unless otherwise specified, $V_{IN2}=12V$ for 3.3V, $I_{LOAD} = 0.5A$

Sym.	Parameter		Conditions	Min.	Typ.	Max.	Unit
I_{B1}	Feedback Bias Current		$V_{FB1}=1.3V$ (Adjustable version only)		-10	-50 -100	nA
F_{OSC}	Oscillator Frequency			127 110	150	173 173	KHz
F_{SCP}	Oscillator Frequency of Short Circuit Protect		When current limit occurred and $V_{FB1} < 0.5V$, $T_a=25^\circ C$	5	15	25	KHz
V_{SAT1}	Saturation Voltage		$I_{OUT1}=2A$ No outside circuit $V_{FB1}=0V$ force driver on		1.25	1.4 1.5	V
DC	Max. Duty Cycle (ON)		$V_{FB}=0V$ force driver on		100		%
	Min. Duty Cycle (OFF)		$V_{FB}=12V$ force driver off		0		
I_{CL1}	Current Limit		Peak current No outside circuit $V_{FB1}=0V$ force driver on	3.5			A
I_L	Output = 0	Output Leakage Current	No outside circuit $V_{FB1}=12V$ force driver off			-200	uA
	Output = -1	Current	$V_{IN1}=22V$		-5		mA
I_Q	Quiescent Current		$V_{FB1}=12V$ force driver off		5	10	mA
I_{STBY}	Standby Quiescent Current		ON/OFF pin=5V $V_{IN1}=22V$		70	150 200	uA
	V_{IL}	ON/OFF Pin Logic Input	Low (regulator ON)	-	1.3	0.6	
V_{IH}	Threshold Voltage	High (regulator OFF)	2.0	-			
I_H	ON/OFF Pin Logic Input Current		$V_{LOGIC}=2.5V$ (OFF)			-0.01	uA
I_L	ON/OFF Pin Input Current		$V_{LOGIC}=0.5V$ (ON)		-0.1	-1	
θ_{JC}	Thermal Resistance		SOP-16L Junction to case		10		°C/W
θ_{JA}	Thermal Resistance with Copper Area of Approximately $15\text{ in}^2 + 15\text{ in}^2$		SOP-16L Junction to ambient		40		°C/W

Not Recommended for New Design



AP1516

150KHz, 3A PWM Buck DC/DC Converter + 1A Ultra Low Drop Regulator

■ Electrical Characteristics (Continued)

Unless otherwise specified, these specifications apply over, $C_{IN}=1\mu F$, $C_{OUT}=10\mu F$, and $T_J=0$ to $150^\circ C$. Typical value refer to $T_J=25^\circ C$. $V_{OUT} = V_{SENSE}$.

Sym.	Parameter	Test Condition	Min.	Typ.	Max.	Unit
V_{REF}	Reference Voltage	$T_J=25^\circ C, (V_{IN2}-V_{OUT2})=0.5V, I_O=10mA, V_B=V_{IN2}+1V$	1.225	1.250	1.275	V
	Line Regulation	$I_{O2}=10mA, V_{OUT2}+0.5V < V_{IN2} < 12V, V_B=V_{IN2}+1V$			0.2	%
	Load Regulation	$0mA < I_{O2} < 1.0A, T_J=25^\circ C, (V_{IN2}-V_{OUT2})=2V, V_B=V_{IN2}+1V$			1	%
	Dropout Voltage (V_B-V_{OUT2})	$V_{FB2}=0V$ for all conditions below. $V_{IN2}=2.05V, I_{O2}=1.0A$		1.5	1.7	V
	Dropout Voltage ($V_{IN2}-V_{OUT2}$)	$V_{FB2}=0V$ for all conditions below. $V_B=3V, I_{O2}=1.0A$		0.5	0.6	V
	Current Limit	$V_B=3V, V_{IN2}=2.05V, \Delta V_O=100mV, V_{FB2}=0V$	1.1			A
	Minimum Load Current	$V_B=5V, V_{IN2}=3.3V, V_{FB2}=0V$		5	10	mA
	Thermal Regulation	30ms Pulse		0.01	0.02	%W
	Ripple Rejection	$V_B=5V, V_{IN2}=5V, I_{O2}=1.0A, V_{FB2}=0V, T_J=25, V_{RIPPLE}=1V_{pp}$ at 120Hz	60	70		dB
	Control Pin Current	$V_{FB2}=0V$ for all conditions below. $V_B=2.75V, V_{IN2}=2.05V, I_{O2}=1.0A$		6	10	mA
	Adjust Pin Current	$V_B=2.75V, V_{IN2}=2.05V, V_{FB2}=0$		50	120	μA

	Symbol	Parameter	Conditions	Typ.	Limit	Unit
AP1516-ADJ	V_{FB1}	Output Feedback	$4.5V \leq V_{IN1} \leq 22V$ $0.2A \leq I_{LOAD1} \leq 3A$ V_{OUT} programmed for 3V	1.23	1.193/1.18 1.267/1.28	V V_{MIN} V_{MAX}
	η	Efficiency	$V_{IN1}=12V, I_{LOAD1}=3A$	74		%
AP1516-3.3V	V_{OUT1}	Output voltage	$4.75V \leq V_{IN1} \leq 22V$ $0.2A \leq I_{LOAD1} \leq 3A$	3.3	3.168/3.135 3.432/3.465	V V_{MIN} V_{MAX}
	η	Efficiency	$V_{IN1}=12V, I_{LOAD1}=3A$	76		%

Specifications with **boldface type** are for full operating temperature range, the other type are for $T_J=25^\circ C$.

Not Recommended for New Design



AP1516

150KHz, 3A PWM Buck DC/DC Converter + 1A Ultra Low Drop Regulator

■ Typical Application Circuit

(1) AP1516-3.3 Fix Version

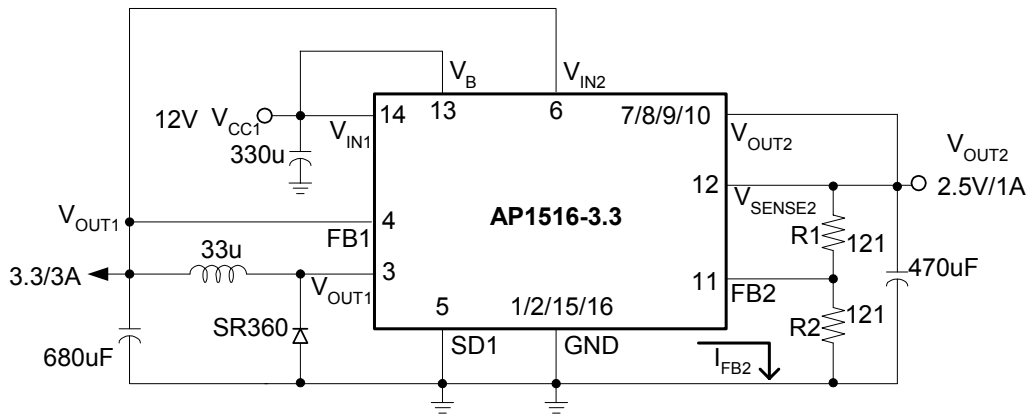

- * $R1 \text{ \& \ } R2 = 100 \sim 200 \text{ ohm}$
- * $V_{OUT2} = 1.235(1 + R2/R1) + I_{FB2} * R2$

(2) AP1516-ADJ Version

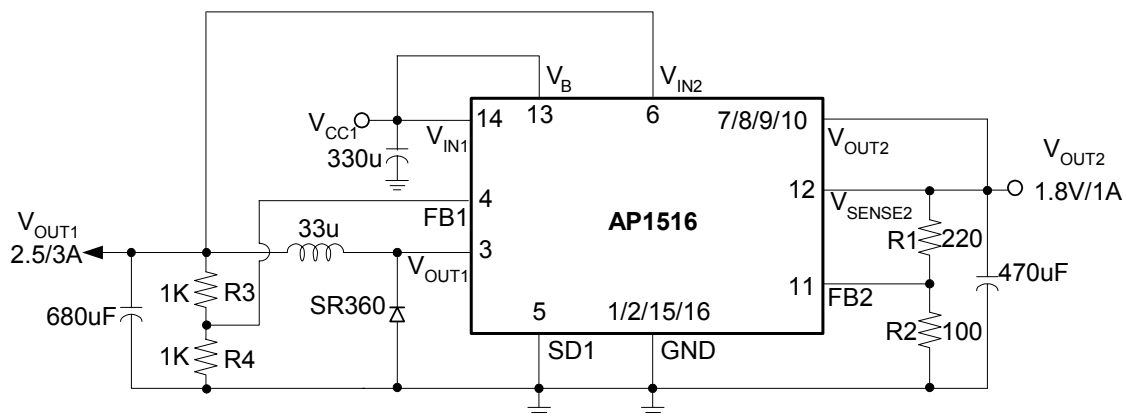

- * $R1 = 200 \sim 300 \text{ ohm}$
- * $R4 = 1K \sim 2K$
- * $V_{OUT1} = 1.235 * (1 + R3/R4)$

Not Recommended for New Design



AP1516

150KHz, 3A PWM Buck DC/DC Converter + 1A Ultra Low Drop Regulator

■ Typical Performance Characteristics

AP1516 Efficiency v.s. Temperature
($V_{IN1}=12V$, $V_{OUT1}=5V$, $I_{O1}=3A$)

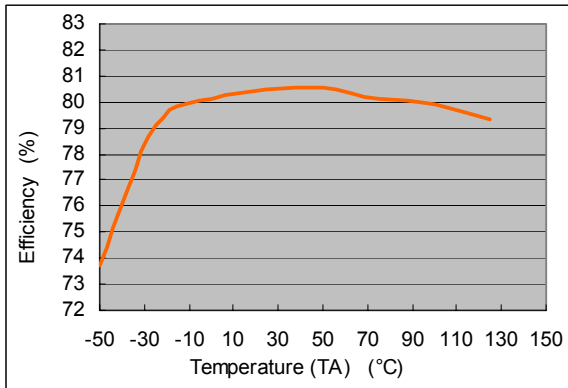

AP1516 Efficiency v.s. Temperature
($V_{IN1}=12V$, $V_{OUT1}=3.3V$, $I_{O1}=3A$)

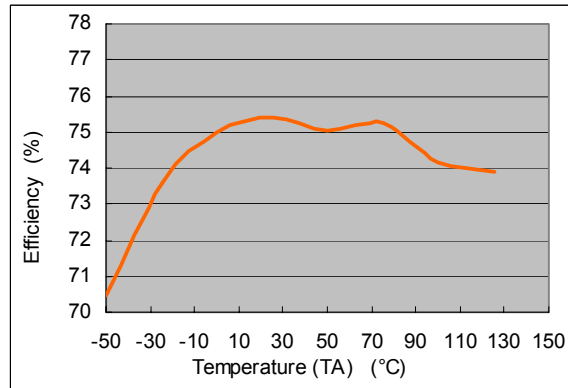

AP1516 Saturation Voltage v.s. Temperature
($V_{IN1}=12V$, $V_{FB1}=0V$, $V_{SD1}=0$)

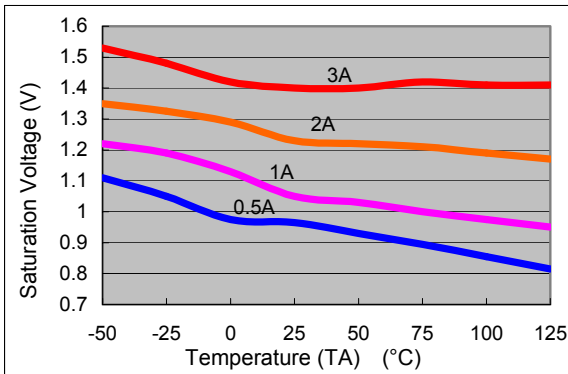

AP1516 Switch Current Limit v.s. Temperature
($V_{IN1}=12V$, $V_{FB1}=0V$)

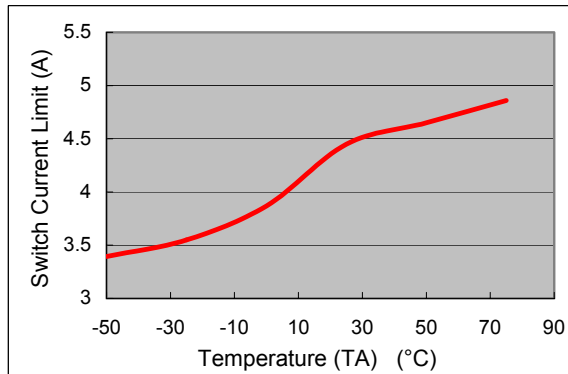

AP1516 Supply Current v.s. Temperature
($V_{IN1}=12V$, No Load, $V_{SD1}=0V$ (Switch ON), $V_{SD1}=5V$ (Switch OFF))

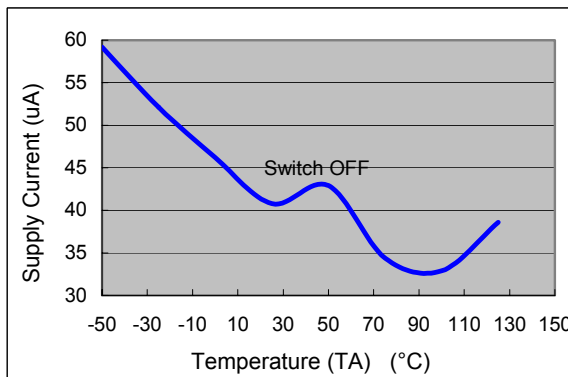
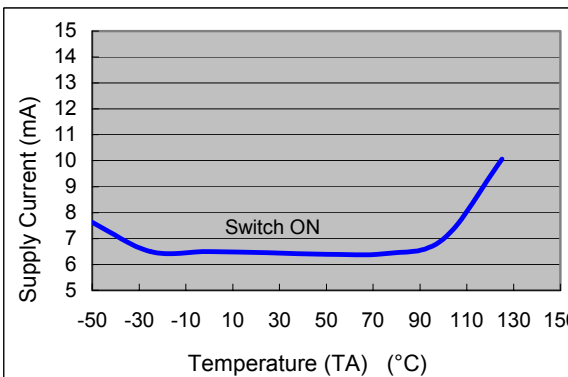

Not Recommended for New Design



AP1516

150KHz, 3A PWM Buck DC/DC Converter + 1A Ultra Low Drop Regulator

■ Typical Performance Characteristics (Continued)

AP1516 Threshold Voltage v.s. Temperature
($V_{IN1}=12V$, $I_{O1}=100mA$)

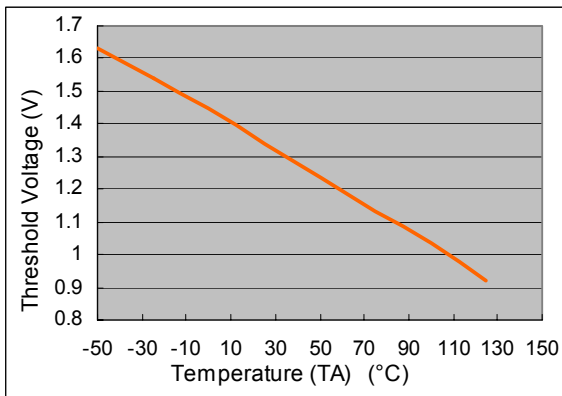

AP1516 ON/OFF Current v.s. ON/OFF Voltage
($V_{IN1}=12V$)

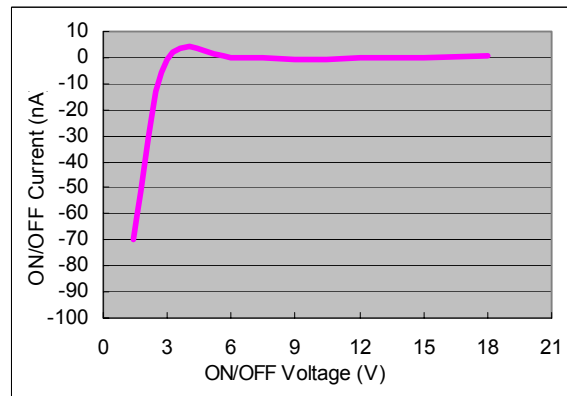

AP1516 Frequency v.s. Temperature
($V_{IN1}=12V$, $I_{O1}=500mA$, $V_{OUT1}=5V$)

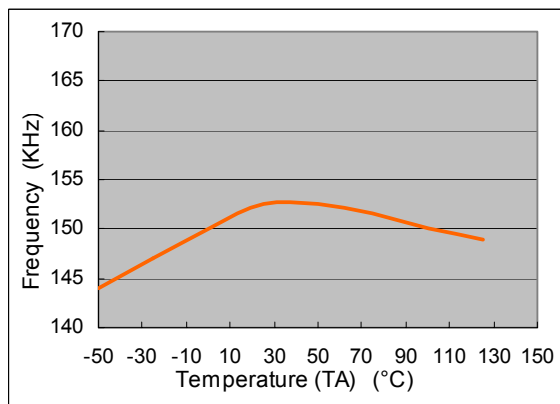

AP1516 Feedback Current v.s. Temperature
($V_{IN1}=12V$, $V_{OUT1}=5V$, $V_{FB1}=1.3V$)

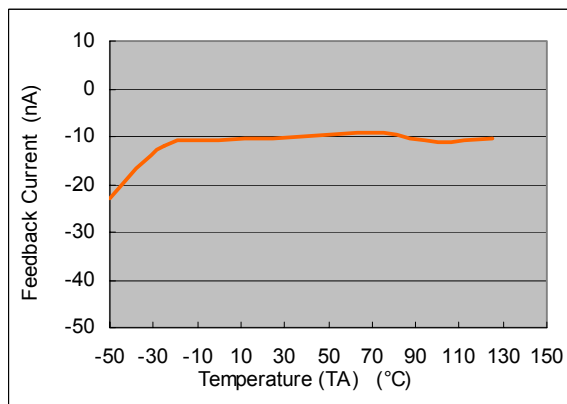

AP1516 Output Voltage v.s. Temperature
($V_{IN1}=12V$, $I_{O1}=3A$)

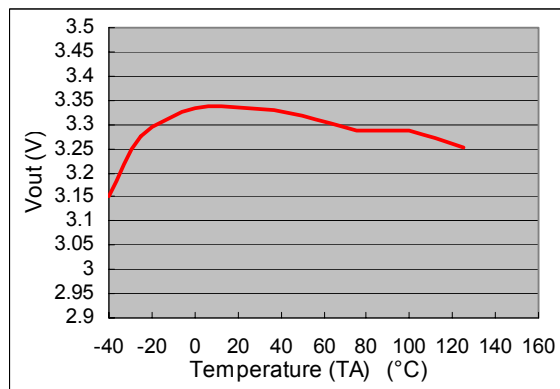

Not Recommended for New Design



AP1516

150KHz, 3A PWM Buck DC/DC Converter + 1A Ultra Low Drop Regulator

■ Function Description

Pin Functions

+V_{IN, B}

This is the positive input supply for the IC switching regulator. A suitable input bypass capacitor must be present at this pin to minimize voltage transients and to supply the switching currents needed by the regulator.

Ground

Circuit ground.

V_{OUT1}

Internal switch. The voltage at this pin switches between (+V_{IN1} - V_{SAT}) and approximately -0.5V, with a duty cycle of approximately V_{OUT1} / V_{IN1}. To minimize coupling to sensitive circuitry, the PC board copper area connected to this pin should be kept a minimum.

Feedback

Senses the regulated output voltage to complete the feedback loop.

SD

Allows the switching regulator circuit to be shutdown using logic level signals thus dropping the total input supply current to approximately 150uA. Pulling this pin below a threshold voltage of approximately 1.3V turns the regulator on, and pulling this pin above 1.3V (up to a maximum of 18V) shuts the regulator down. If this shutdown feature is not needed, the SD pin can be wired to the ground pin.

Introduction

The channel 2 regulator is an extremely low dropout voltage comparable to the PNP type without the disadvantage of the extra power dissipation due to the base current associated with PNP regulators. This is done by bringing out the control pin of the regulator that provides the base current to the power NPN and connecting it to a voltage that is greater than the voltage present at the V_{IN2} pin. This flexibility makes the channel 2 ideal for applications where dual inputs are available such as a computer motherboard with an ATX style power supply that provides 5V and 3.3V to the board. One such application is the new graphic chip sets that require anywhere from 2.4V to 2.7V supply. The channel 2-ADJ can easily be programmed with the addition

of two external resistors to any voltages within the range of 1.25V to 15.5V. Another major requirement of these graphic chips is the need to switch the load current from zero to several amps in tens of nanoseconds at the processor pins, which translates to an approximately 300 to 500ns of current step at the regulator. In addition, the output voltage tolerances are also extremely tight and they include the transient response as part of the specification.

The channel 2 is specifically designed to meet the fast current transient needs as well as providing an accurate initial voltage, reducing the overall system cost with the need for fewer number of output capacitors. Another feature of the device is its true remote sensing capability that allows accurate voltage setting at the load rather than at the device.

Output Voltage Setting

The channel 2 can be programmed to any voltages in the range of 1.25V to 15.5V with the addition of R1 and R2 external resistors according to the following formula:

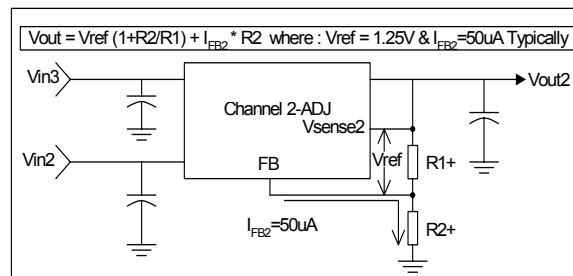

The channel 2 keeps a constant 1.25V between the V_{SENSE} pin and the FB2 pin. By placing a resistor R1 across these two pins and connecting the V_{SENSE} and V_{OUT} pin together, a constant current flows through R1, adding to the I_{FB2} current and into the R2 resistor producing a voltage equal to the (1.25/R1)*R2 + I_{FB2}*R2. This voltage is then added to the 1.25V to set the output voltage. This is summarized in the above equation.

Not Recommended for New Design



AP1516

150KHz, 3A PWM Buck DC/DC Converter + 1A Ultra Low Drop Regulator

■ Function Description (Continued)

Since the minimum load current requirement of the channel 2 is 10mA, R1 is typically selected to be a 121Ω resistor so that it automatically satisfies this condition. Notice that since the I_{FB2} is typically in the range of 50uA it only adds a small error to the output voltage and should be considered when very precise output voltage setting is required.

Load Regulation

Since the channel 2 has separate pins for the output (V_{OUT2}) and the sense (V_{SENSE2}), it is ideal for providing true remote sensing of the output voltage at the load. This means that the voltage drops due to parasitic resistance such as PCB traces between the regulator and the load are compensated for using remote sensing. Figure following shows a typical application of the channel 2 with remote sensing.

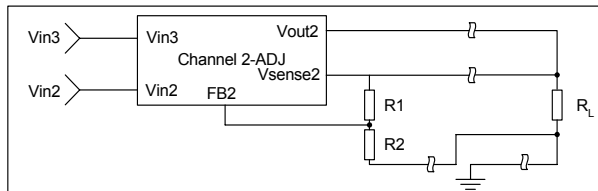

Stability

The channel 2 requires the use of an output capacitor as part of the frequency compensation in order to make the regulator stable. Typical designs for the microprocessor applications use standard electrolytic capacitors with typical ESR in the range of 50 to 100mΩ and an output capacitance of 100uF to 1000uF. Fortunately as the capacitance increases, the ESR decreases resulting in a fixed RC time constant. The channel 2 takes advantage of the phenomena in making the overall regulator loop stable.

For most applications a minimum of 100uF aluminum electrolytic capacitor insures both stability and good transient response.

Thermal Considerations

The SOP-16 package needs a heat sink under most conditions. The size of the heatsink depends on the input voltage, the output voltage, the load current and the ambient temperature. The AP1516 junction temperature rises above ambient temperature for a 3A load and different input and output voltages.

For the best thermal performance, wide copper traces and generous amounts of printed circuit board copper should be used in the board layout. (Once exception to this is the output (switch) pin, which should not have large areas of copper.) Large areas of copper provide the best transfer of heat (lower thermal resistance) to the surrounding air, and moving air lowers the thermal resistance even further.

Package thermal resistance and junction temperature rise numbers are all approximate, and there are many factors that will affect these numbers. Some of these factors include board size, shape, thickness, position, location, and even board temperature. Other factors are, trace width, total printed circuit copper area, copper thickness, single or double-sided, multi-layer board and the amount of solder on the board.

The effectiveness of the PC board to dissipate heat also depends on the size, quantity and spacing of other components on the board, as well as whether the surrounding air is still or moving. Furthermore, some of these components such as the catch diode will add heat to the PC board and the heat can vary as the input voltage changes. For the inductor, depending on the physical size, type of core material and the DC resistance, it could either act as a heat sink taking heat away from the board, or it could add heat to the board.

Not Recommended for New Design



AP1516

150KHz, 3A PWM Buck DC/DC Converter + 1A Ultra Low Drop Regulator

■ Marking Information

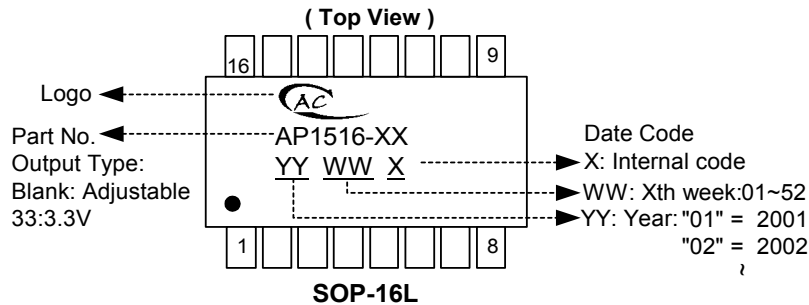

■ Package Information

Package Type: SOP-16L

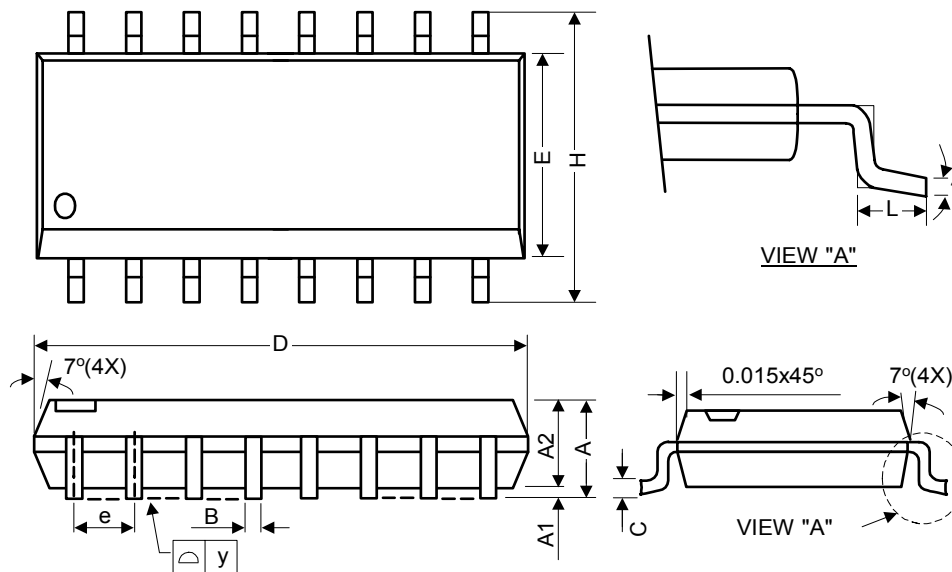

Symbol	Dimensions In Millimeters			Dimensions In Inches		
	Min.	Nom.	Max.	Min.	Nom.	Max.
A	1.40	1.60	1.75	0.055	0.063	0.069
A1	0.10	-	0.25	0.040	-	0.010
A2	1.30	1.45	1.50	0.051	0.057	0.059
B	0.33	0.41	0.51	0.013	0.016	0.020
C	0.19	0.20	0.25	0.0075	0.008	0.0098
D	9.80	9.90	10.00	0.386	0.390	0.394
E	3.80	3.90	4.00	0.150	0.154	0.157
e	-	1.27	-	-	0.050	-
H	5.80	6.00	6.20	0.228	0.236	0.244
L	0.38	0.71	1.27	0.015	0.028	0.050
Θ	0	-	8	0	-	8